

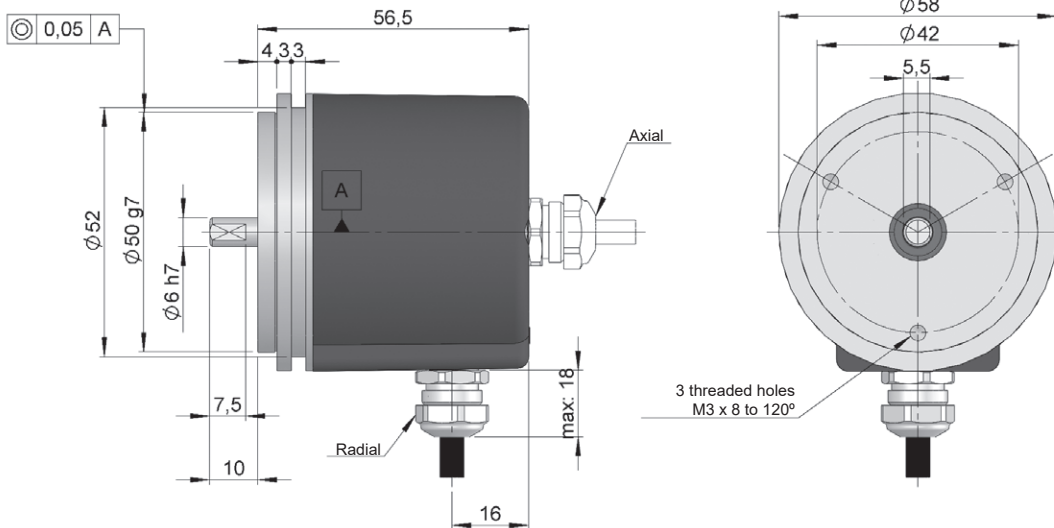

SERIE 58

HIGH RESOLUTION INCREMENTAL SOLID SHAFT ENCODER FOR INDUSTRIAL APPLICATIONS

- Resolution up to 50.000 pulses per turn
- External diameter 58 mm
- Shaft \varnothing 6 mm
- Fixation through synchro flange
- Protection class IP65 according to DIN EN 60529
- Connection by cable (other cable length available) or industrial connector M12, M23
- Female connector included



Drawing shaft type 1, connection type 1/2, without flange

REFERENCE

Reference example: 58-11111-1024

Serie	Shaft	Flange	Output signals	Connection	Power Supply / Electronic output	Pulses number	Special customer
58 -	<input type="checkbox"/>	<input type="checkbox"/>	<input type="checkbox"/>	<input type="checkbox"/>	<input type="checkbox"/> -	<input type="checkbox"/> <input type="checkbox"/> <input type="checkbox"/> <input type="checkbox"/> <input type="checkbox"/> <input type="checkbox"/>	<input type="checkbox"/> <input type="checkbox"/> <input type="checkbox"/> <input type="checkbox"/> <input type="checkbox"/> <input type="checkbox"/>
	1. \varnothing 6x10 mm	1. None	1. A \tilde{A} +B \tilde{B} +0 $\tilde{0}$ 2. A \tilde{A} +B \tilde{B} 3. A+B	1. Axial cable 2. Radial cable 3. Axial 90.9512 4. Radial 90.9512 5. Axial 90.9508 6. Radial 90.9508	0. 11...30 VDC / NPN Open collector 11...30 VDC 1. 11...30 VDC / Line driver differential Push-Pull 11...30 VDC 2. 5 VDC / RS422 5 VDC (compatible TTL) 5. 11...30 VDC / RS422 5 VDC (compatible TTL)	(*)	BT00. -40°C

Order your reference
Step file 3D

info@encoderhohner.com
service available in 24 h

(*) 10.000 to 50.000 pulses with interpolation. Available 10.000 direct optical pulses without interpolating upon request.



SERIE 58

HIGH RESOLUTION INCREMENTAL SOLID SHAFT ENCODER FOR INDUSTRIAL APPLICATIONS

MECHANICAL SPECIFICATIONS

Materials	Cover: Aluminium Housing: Aluminium Shaft: Stainless Steel
Bearings	Ballraces
Bearings lifetime	1x10 ¹⁰ rev.
Maximum number of revolutions permitted mechanically	6000 rpm
Protection against dust and splashes according to DIN EN 60529	IP65
Rotor inertia moment	30 gcm ²
Starting torque at 20°C (68°F)	≤ 0,02 Nm
Maximum load permitted on axial shaft	40 N
Maximum load permitted on radial shaft	60 N
Weight approx.	0,5 Kg
Operating temperature range	-20°C to +80°C - Standard -40°C to +80°C - Special Customer BT00
Vibration according to DIN EN 60068-2-6	100 m/s ² (10Hz...2000Hz)
Shock according to DIN EN 60068-2-27	1000 m/s ² (6ms)
Maximum pulses per turn	50.000
Axial or radial connection	2 meters cable or industrial connector M12, M23 (other cable lenghts available on order) Female connector included

OUTPUT SIGNALS

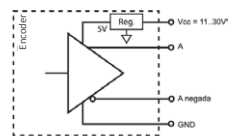
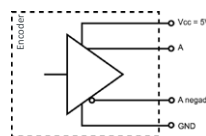
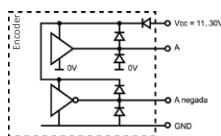
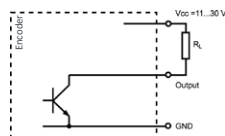

OUTPUT CIRCUIT	NPN Open Collector	Push-Pull Differential	RS422 (TTL compatible)	RS422 (TTL compatible)
Reference code	0	1	2	6
Power supply	11...30 VDC	11...30 VDC	5 VDC ±5%	11...30 VDC
Output voltage	11...30 VDC	11...30 VDC	5 VDC	5 VDC
Consumption	40 mA	Typical: 45 mA Max: 150 mA	Typical: 70 mA Max: 150 mA	Typical: 80 mA Max: 160 mA
Max. load capability / channel	40 mA	±30 mA	±20 mA	±20 mA
Lenght of cable allowed	50 m (24 VDC)	100 m	1200 m	1200 m
"Low" signal level	VOL < 0.4 VDC (24 VDC)	VOL < 2.5 VDC	VOL < 0.5 VDC	VOL < 0.5 VDC
"High" signal level	VOH > 22 VDC (24 VDC)	VOH > VCC – 3 VDC	VOH > 2.5 VDC	VOH > 2.5 VDC
Frequency	100 kHz	200 kHz	300 kHz	300 kHz
Short circuit protection	Not permanent	Yes	Yes	Yes
Protection polarity inversion	Yes	Yes	No	Yes

Channel B leads (90° electric) channel A, view from the shaft, shaft rotating clockwise

SERIE 58

HIGH RESOLUTION INCREMENTAL SOLID SHAFT ENCODER FOR INDUSTRIAL APPLICATIONS

CONNECTION



	95.0008002 Cable 2x2x0,14+1x0,14	95.0008003 (* Cable 3x2x0,14+2x0,34	90.9508 M12 8p CCW	90.9512 M23 12p CW
GND	Yellow	Black	1	1
VCC	White	Red	2	2
A	Brown	Yellow	3	3
B	Green	Green	4	4
\tilde{A}		Brown	5	5
\tilde{B}		Blue	6	6
0 (reference)	Grey	Grey	7	7
$\tilde{0}$	Grey	Orange	8	8

(* Cable 3x2x0,14+2x0,34 only for encoders with inverted signals.

ACCESSORIES EXAMPLES

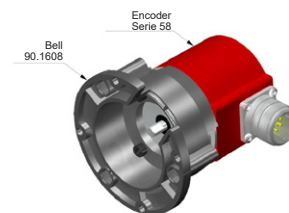
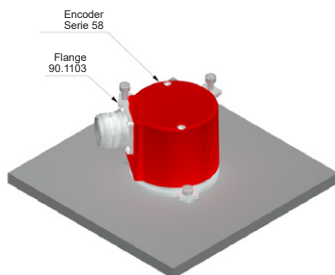
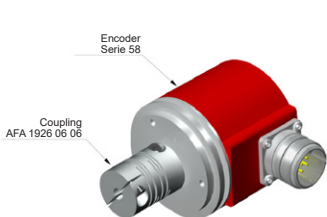

All the accessories available in the section "MOUNTING ACCESSORIES".

CONNECTION DIMENSIONS

Female connector included

Connection 3

Axial 90.9512

Connection 4

Radial 90.9512

90.9512

M23 12p
male panel
clockwise

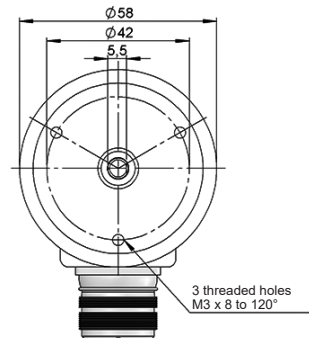
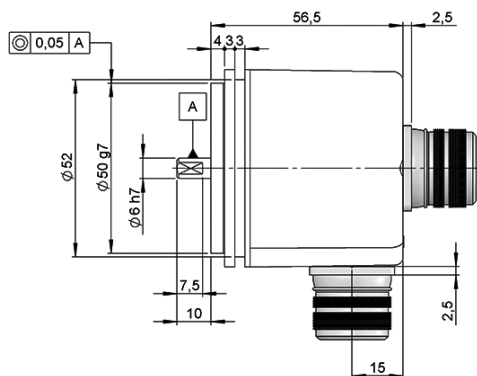

90.9512

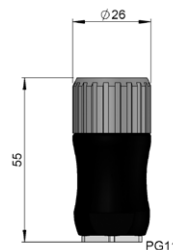

SERIE 58

HIGH RESOLUTION INCREMENTAL SOLID SHAFT ENCODER FOR INDUSTRIAL APPLICATIONS

Connection 5

Axial 90.9508

Connection 6

Radial 90.9508

90.9508

M12 8p

male panel

counter clockwise

