



Image with flange 90.1008



SERIE 30

HIGH RESOLUTION INCREMENTAL SOLID SHAFT ENCODER FOR HEAVY DUTY INDUSTRIAL APPLICATIONS

- Resolution up to 50.000 pulses per turn
- External diameter 90 mm
- Shaft \varnothing 12 mm
- Protection class IP67 according to DIN EN 60529
- Executions mechanical, electronic and special optics forms available on request
- Connection by cable (other cable length available) or industrial connector
- Female connector included

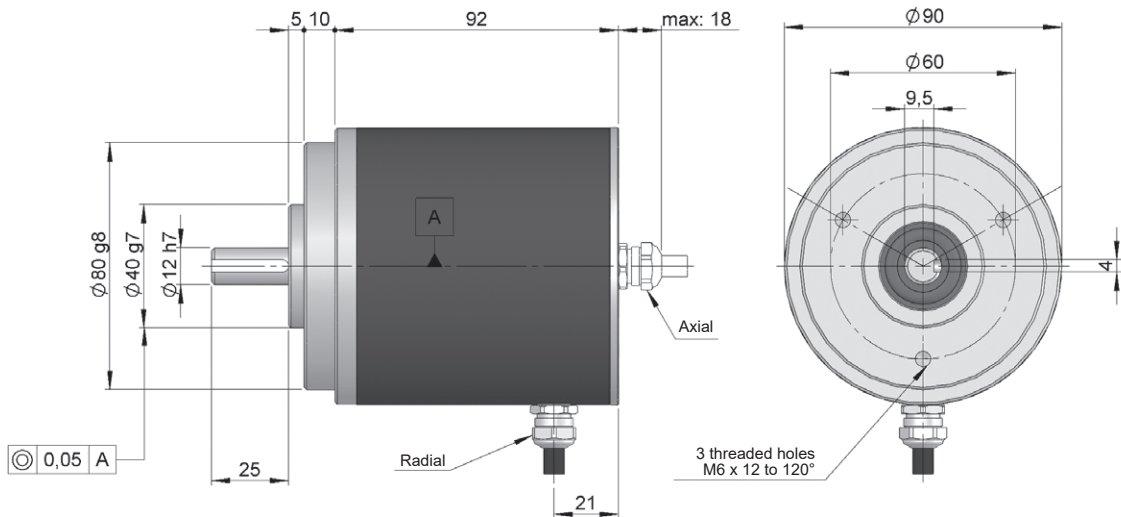

Drawing Encoder Serie 30, connection type 0/5

REFERENCE

Reference example: 30-4251-1024

Serie	Output signals	Connection	Power Supply / Electronic output	Pulses number	Special customer
30/30A -	<input type="checkbox"/> <input type="checkbox"/>	<input type="checkbox"/>	<input type="checkbox"/> -	<input type="checkbox"/> <input type="checkbox"/> <input type="checkbox"/> <input type="checkbox"/> <input type="checkbox"/> <input type="checkbox"/>	<input type="checkbox"/> <input type="checkbox"/> <input type="checkbox"/> <input type="checkbox"/>
30. IP 65	30. A	0. Axial cable	0. 11...30 VDC / NPN Open collector 11..30 VDC	(*)	FT00. -40°C
30A. IP 67 (**)	40. A+B	1. Axial 90.9504	6. 11...30 VDC / RS422 5 VDC (compatible TTL)		
	42. A+B+0	3. Axial 90.9507	7. 5 VDC / RS422 5 VDC (compatible TTL)		
	43. A+B+0	4. Axial 90.9512	9. 11..30 VDC / Line driver differential Push-Pull 11...30 VDC		
	35. A \tilde{A} +B \tilde{B}	5. Radial cable			
	36. A \tilde{A} +B \tilde{B} +0	9. Radial 90.9512			
		M. Axial 90.9510			

Order your reference
Step file 3D

info@encoderhohner.com

service available in 24 h

(*) 10.000 to 50.000 pulses with interpolation. Available 10.000 direct optical pulses without interpolating upon request.

(**) The option 30A is only available with cable connection output (0/5).



SERIE 30

HIGH RESOLUTION INCREMENTAL SOLID SHAFT ENCODER FOR HEAVY DUTY INDUSTRIAL APPLICATIONS

MECHANICAL SPECIFICATIONS

Materials	Cover: Aluminium Housing: Aluminium Shaft: Stainless Steel
Bearings	Ballraces
Bearings lifetime	1x10 ¹⁰ rev.
Maximum number of revolutions permitted mechanically	6000 rpm
Protection against dust and splashes according to DIN EN 60529	IP65 - Standard IP67 - Option 30A
Rotor inertia moment	270 gcm ²
Starting torque at 20°C (68°F)	≤ 0,05 Nm
Maximum load permitted on axial shaft	80 N
Maximum load permitted on radial shaft	100 N
Weight aprox.	1,2 Kg
Operating temperature range	-20°C to +80°C - Standard -40°C to +80°C - Special Customer FT00
Vibration according to DIN EN 60068-2-6	100 m/s ² (10Hz...2000Hz)
Shock according to DIN EN 60068-2-27	1000 m/s ² (6ms)
Maximum pulses per turn	50.000
Axial or radial connection	2 meters cable or industrial connector (other cable lenghts available on order) Female connector included

OUTPUT SIGNALS



OUTPUT CIRCUIT	NPN Open Collector	RS422 (TTL compatible)	RS422 (TTL compatible)	Push-Pull Differential
Reference code	0	6	7	9
Power supply	11...30 VDC	11...30 VDC	5 VDC ±5%	11...30 VDC
Output voltage	11...30 VDC	5 VDC	5 VDC	11...30 VDC
Consumption	40 mA	Typical: 80 mA Max: 160 mA	Typical: 70 mA Max: 150 mA	Typical: 45 mA Max: 150 mA
Max. load capability / channel	40 mA	±20 mA	±20 mA	±30 mA
Lenght of cable allowed	50 m (24 VDC)	1200 m	1200 m	100 m
"Low" signal level	VOL < 0.4 VDC (24 VDC)	VOL < 0.5 VDC	VOL < 0.5 VDC	VOL < 2.5 VDC
"High" signal level	VOH > 22 VDC (24 VDC)	VOH > 2.5 VDC	VOH > 2.5 VDC	VOH > VCC - 3 VDC
Frequency	100 kHz	300 kHz	300 kHz	200 kHz
Short circuit protection	Not permanent	Yes	Yes	Yes
Protection polarity inversion	Yes	Yes	No	Yes

Channel B leads (90° electric) channel A, view from the shaft, shaft rotating clockwise

SERIE 30

HIGH RESOLUTION INCREMENTAL SOLID SHAFT ENCODER FOR HEAVY DUTY INDUSTRIAL APPLICATIONS

CONNECTION



	95.0008002 Cable 2x2x0,14+1x0,14	95.0008003 (* Cable 3x2x0,14+2x0,34	90.9504 DIN 43650 4p	90.9507 Mil 7p CW	90.9510 Mil 10p CW	90.9512 M23 12p CW
GND	Yellow	Black	1	A	A	1
VCC	White	Red	2	B	B	2
A	Brown	Yellow	3	C	C	3
B	Green	Green	4	D	D	4
\tilde{A}		Brown		E	E	5
\tilde{B}		Blue		F	F	6
0 (reference)	Grey	Grey		G	G	7
$\tilde{0}$	Grey	Orange		G	H	8

(* Cable 3x2x0,14+2x0,34 only for encoders with inverted signals.

ACCESSORIES EXAMPLES

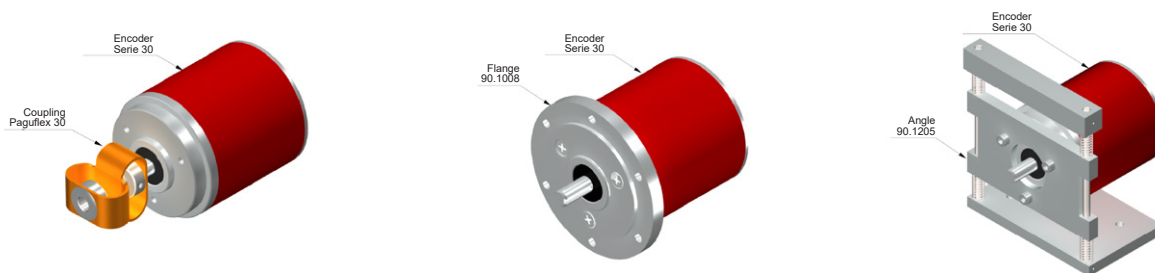

All the accessories available in the section "MOUNTING ACCESSORIES".

CONNECTION DIMENSIONS

Female connector included

Connection 1
Axial 90.9504

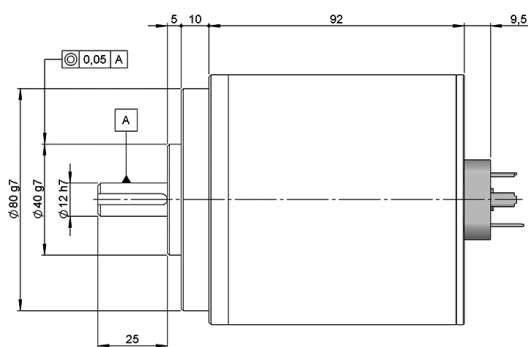

90.9504
DIN 43650 4p
male panel

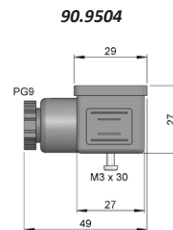
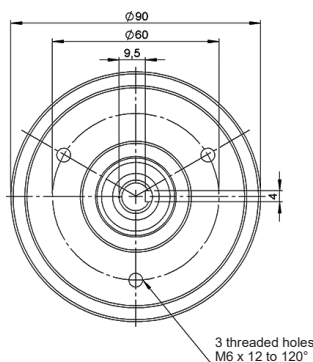

SERIE 30

HIGH RESOLUTION INCREMENTAL SOLID SHAFT ENCODER FOR HEAVY DUTY INDUSTRIAL APPLICATIONS

Connection 3 Axial 90.9507

90.9507
Mil 7p
male panel
clockwise

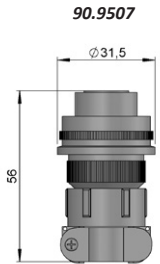
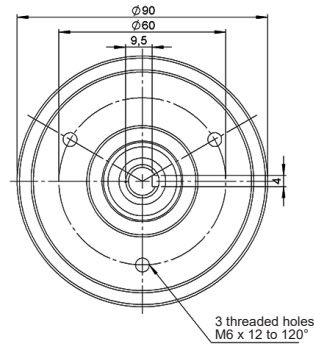
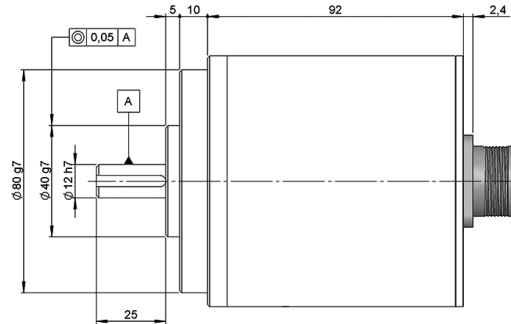

Connection 4 Axial 90.9512

Connection 9 Radial 90.9512

90.9512
M23 12p
male panel
clockwise

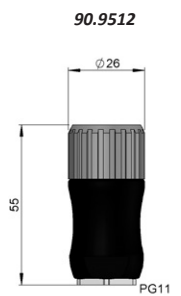
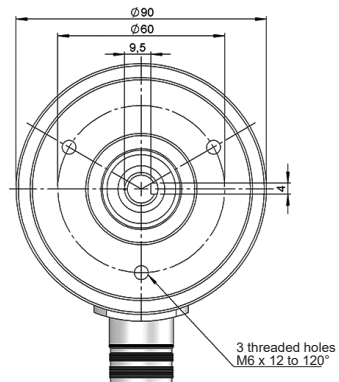
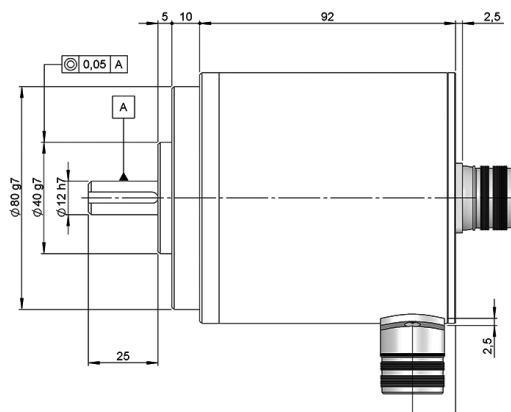

Connection M Axial 90.9510

90.9510
Mil 10p
male panel
clockwise

